

Quick Installation Guide Reference

ComfoAir 350 L Basic

comfosystems

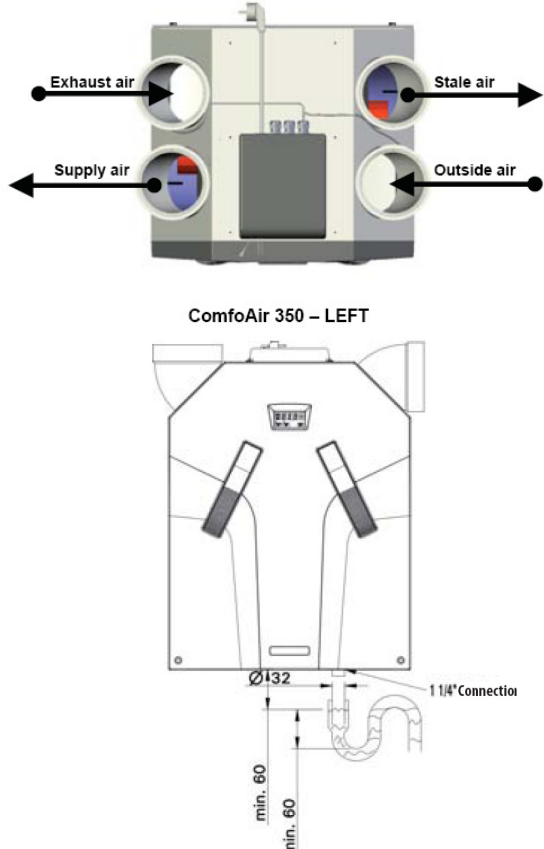
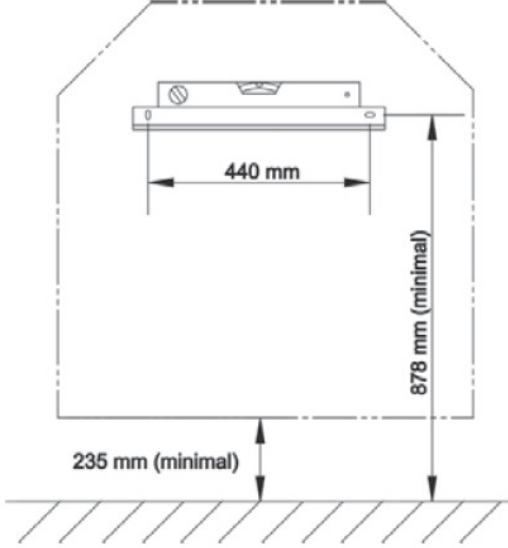

Duct Configuration	Mounting Options	Other
 <p>ComfoAir 350 – LEFT</p>	 <p><i>The place of installation must be chosen so that there is sufficient room around the unit for air duct connections, intake and exhaust piping and in order to carry out maintenance work including replacement of filters.</i></p>	<p>Weight – 39Kg</p> <p>Condensate Drain – 32mm</p> <p>Spigot size – 160mm</p> <p>Voltage – 230 V~, 50 Hz</p>

Quick Installation Guide Reference

ComfoAir 350 L Basic

comfosystems



Wiring

External Wiring for CA350 using 3-position Boost switch (CCBL) with LED Fault Indication

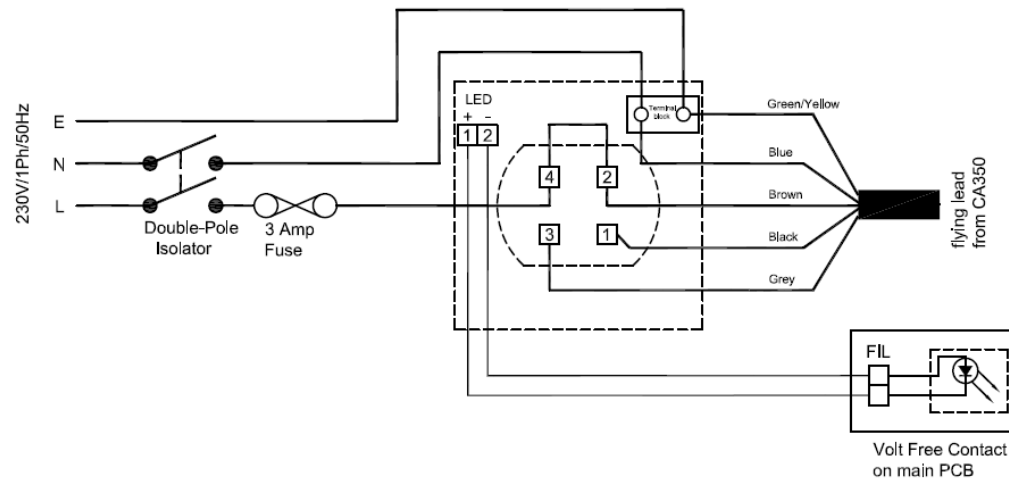

Bathroom Switch

Fan terminals on main PCB

Bathroom Switch Option

A Bathroom Switch can be incorporated via the BS Volt free contacts on the Internal PCB as indicated. Operation of this switch activates a linked delay and overrun timer

Delay Timer factory set to 0mins, adjustable between 0 and 15mins

Overrun Timer factory set to 30mins, adjustable between 0 and 120mins